

KRZESEŁKO SCHODOWE ALFA

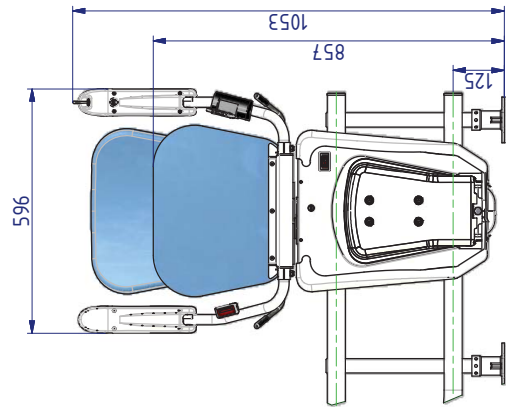

www.pcwindy.pl | pcwindy@pcwindy.pl

POZYCJE OBROTU:
0°, 20°, 45°, 70°, 90°

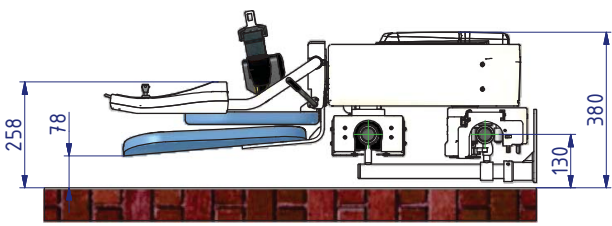
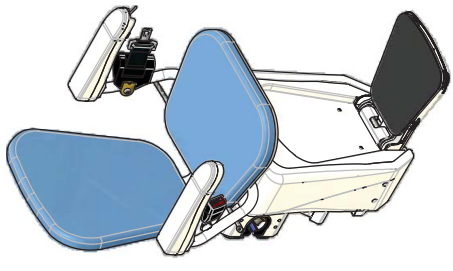
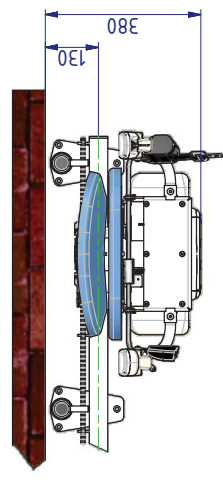
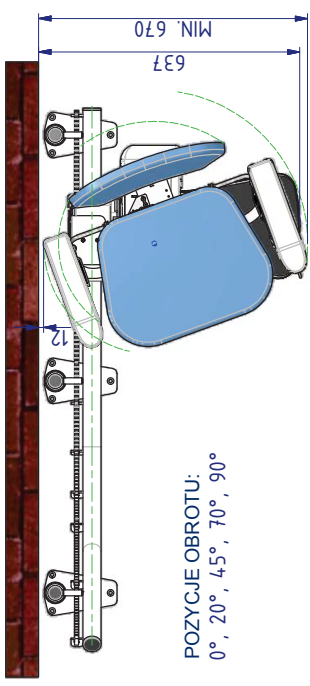
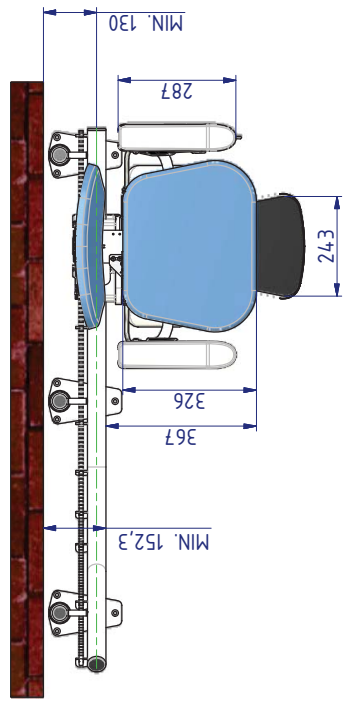
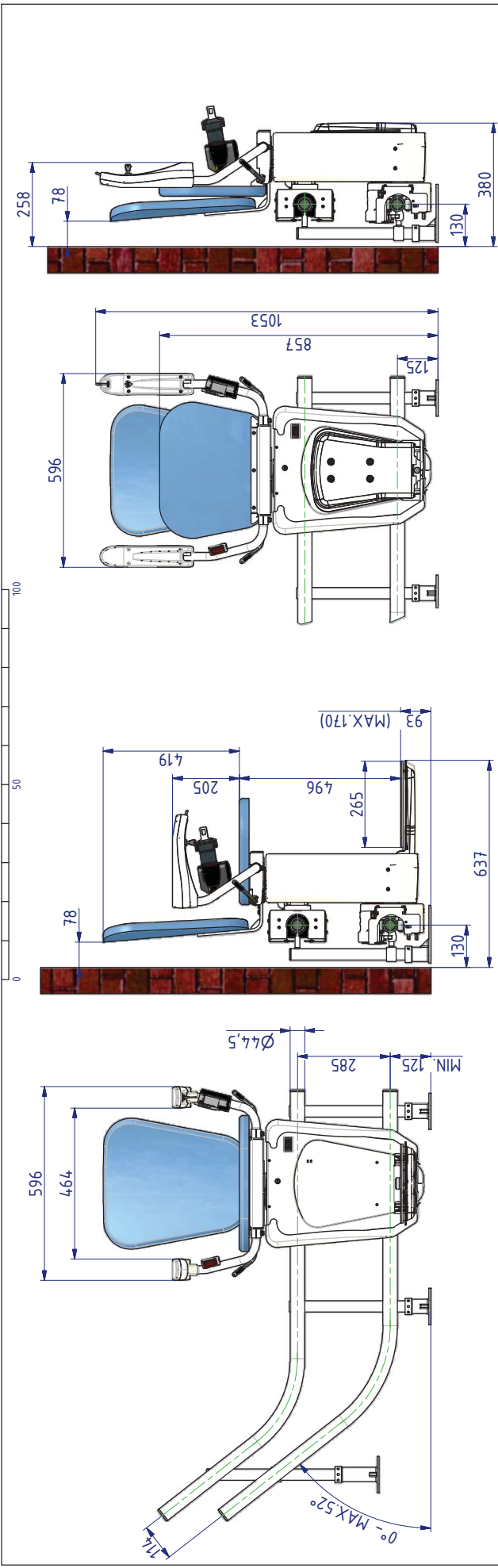

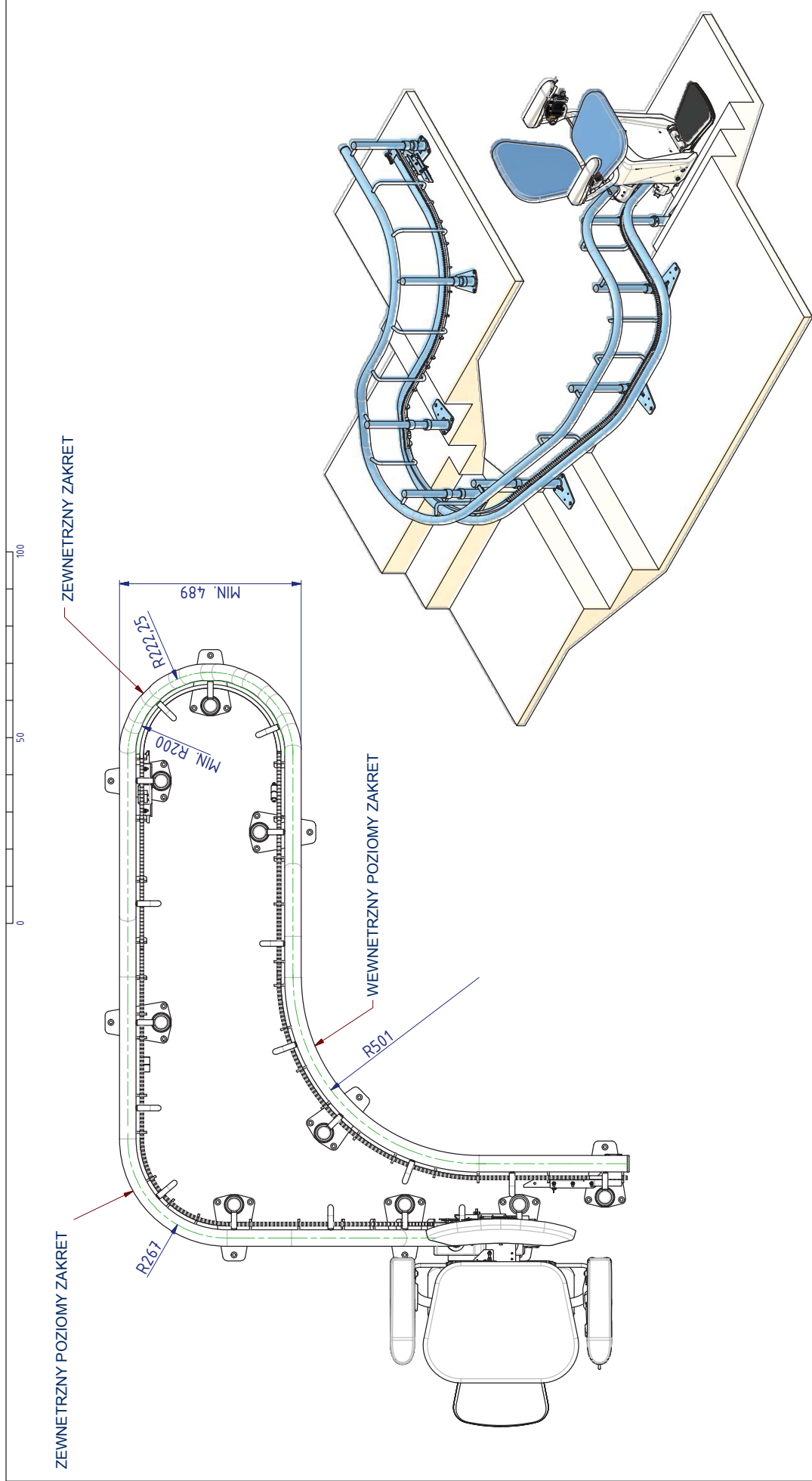

KRZESEŁKO SCHODOWE ALFA

WYMIARY ZAKRĘTÓW



www.pcwindy.pl | pcwindy@pcwindy.pl

PRZYSTANEK DOLNY - BEZ ZAKRĘTÓW

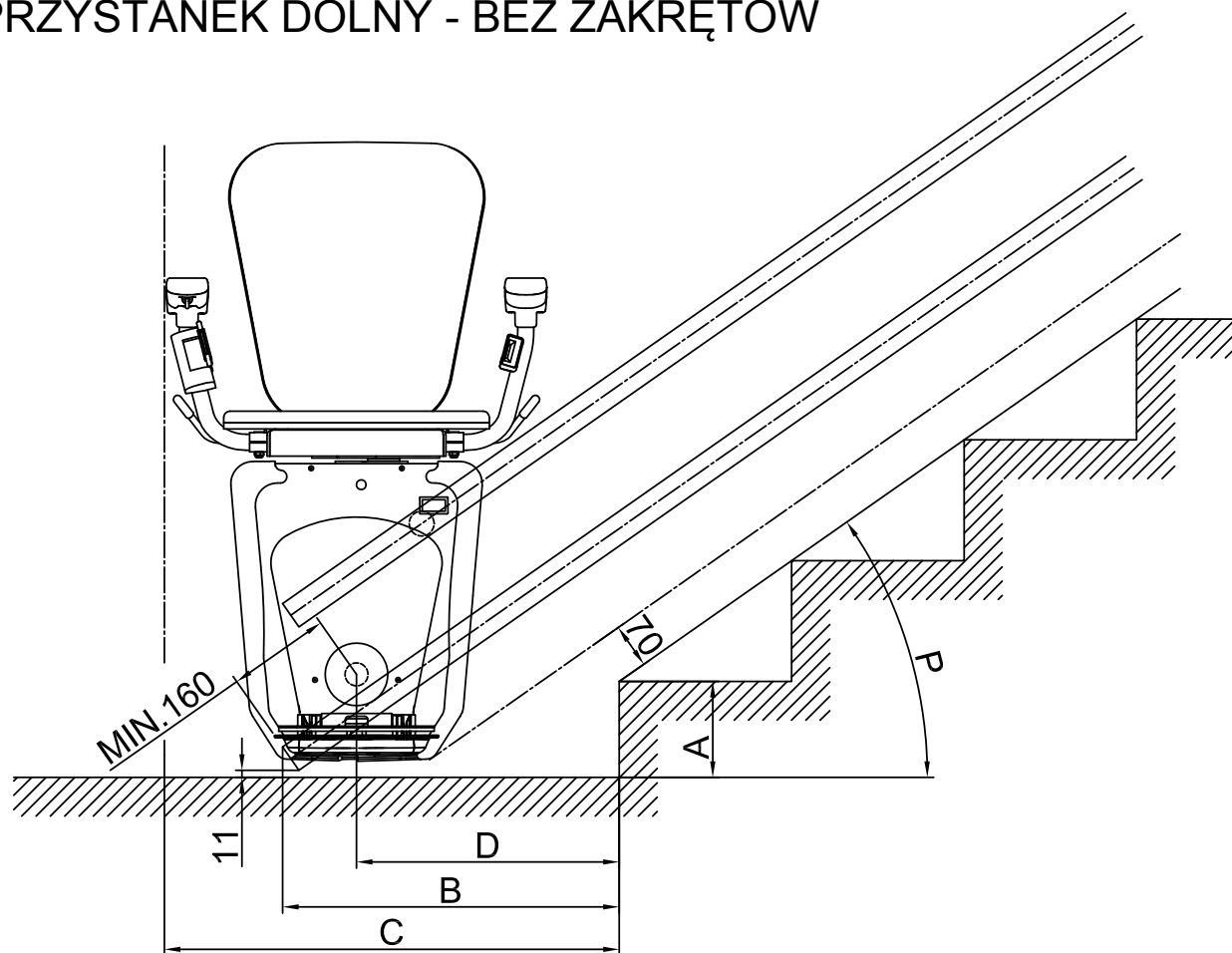

40°	468	663	362	486	679	380	509	703	404
35°	527	712	411	548	732	433	577	760	461
30°	607	783	481	632	807	507	667	841	542
25°	711	880	578	744	910	610	787	952	653
P	B	C	D	B	C	D	B	C	D
	A=150			A=165			A=180		

A ... WYSOKOŚĆ PIERWSZEGO STOPNIA

B ... KONIEC SZYNY

C ... MIEJSCE NA KRZESEŁKO

D ... MIEJSCE ZATRZYMANIA

P ... KĄT NACHYLENIA SCHODÓW

PRZYSTANEK GÓRNY - DO KRAWĘDZI PODESTU

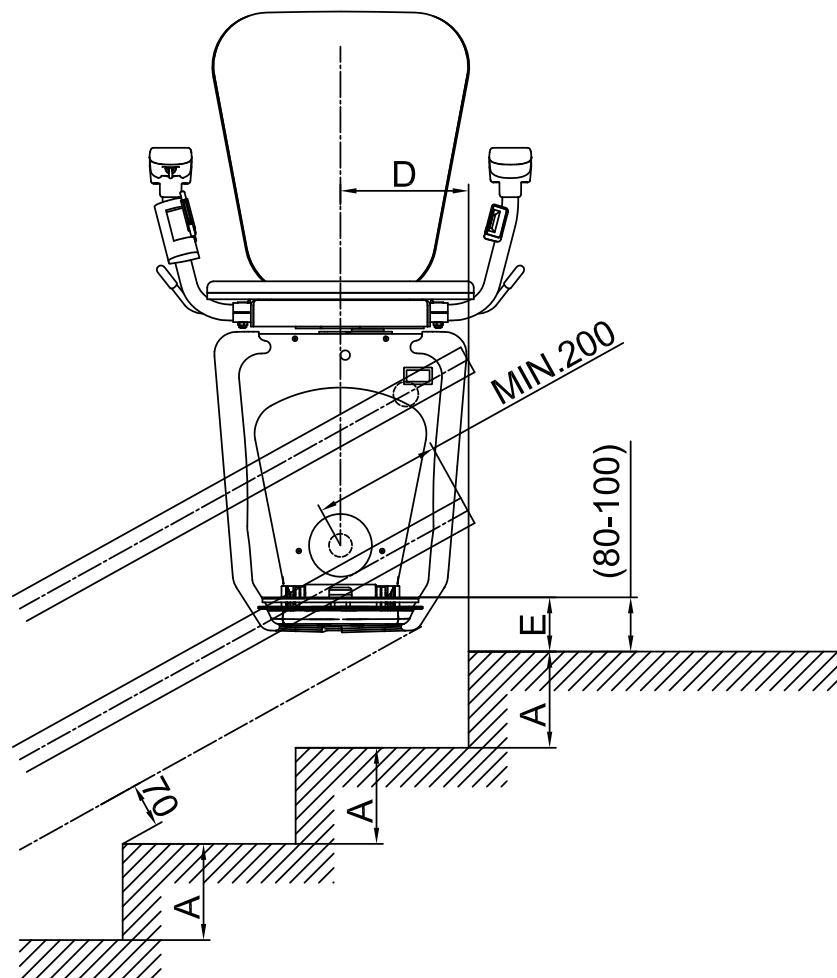

WYSOKOŚĆ STOPNI A	POZYCJA ZATRZYMANIA D	WYSOKOŚĆ DO PONOŻKA E
150	200	85
165	190	88
185	180	93

PRZYSTANEK GÓRNY - NA GÓRNYM PODEŚCIE SCHODÓW

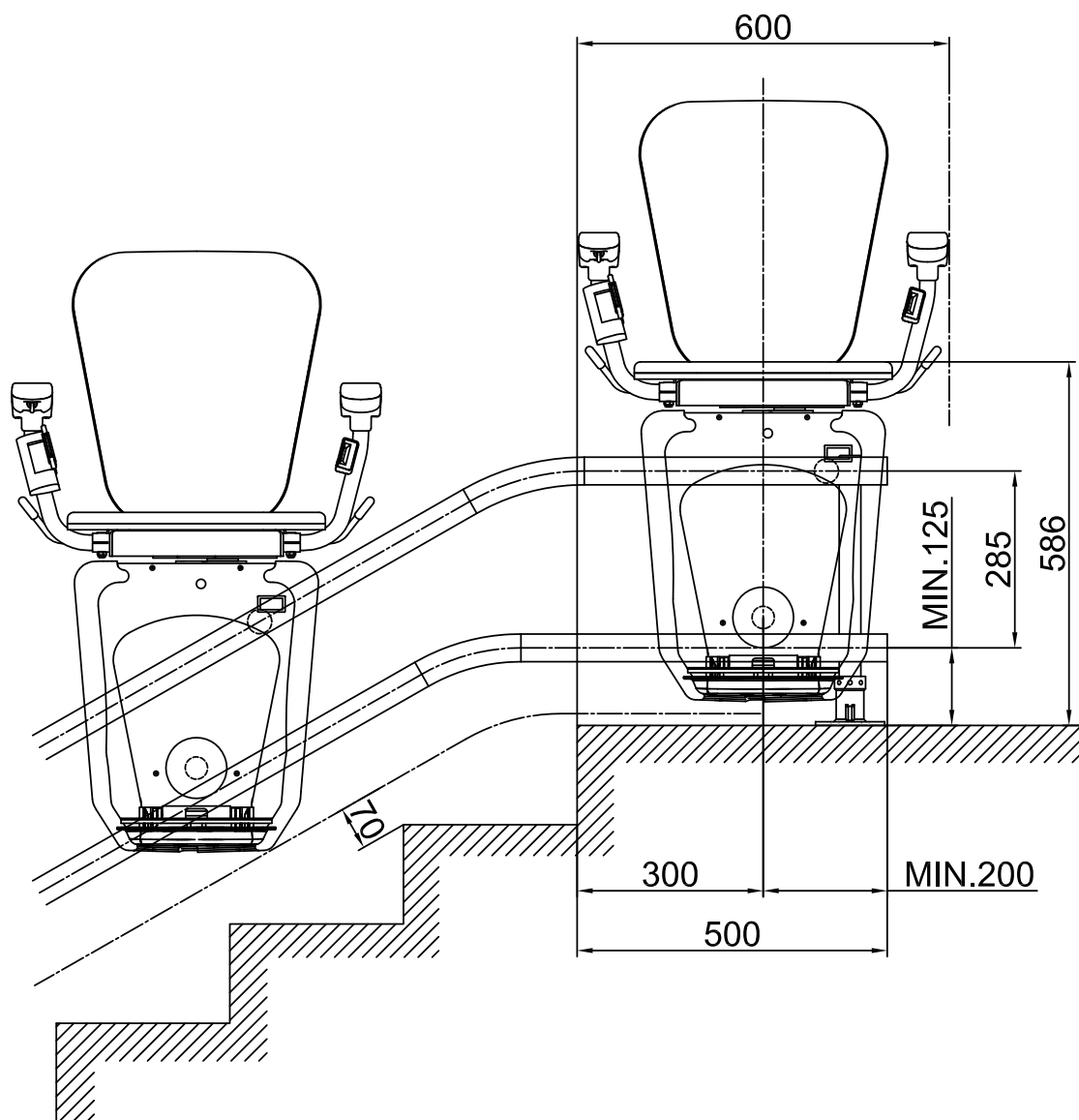

PRZYSTANEK DOLNY - STROMY START

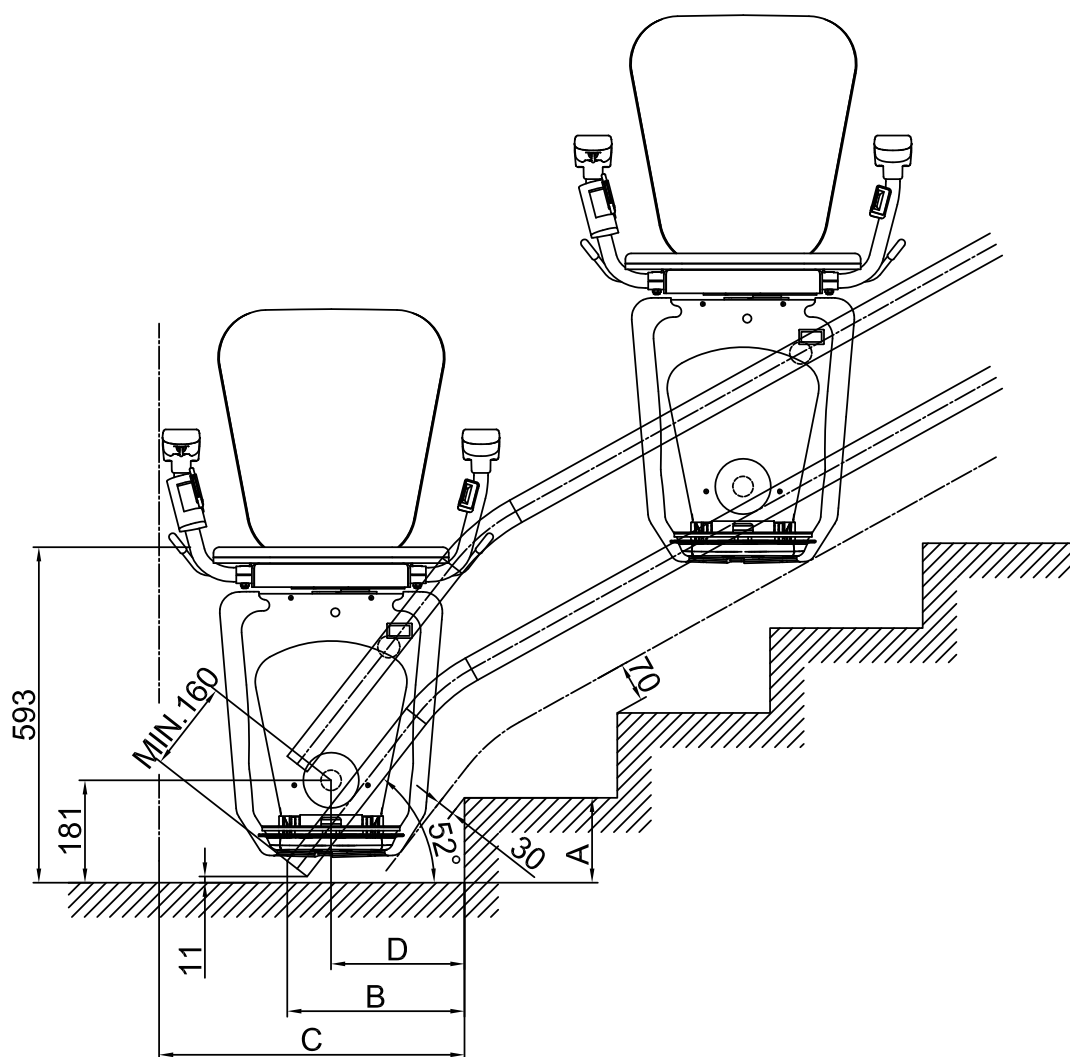

WYSOKOŚĆ PIERWSZEGO STOPNIA A	KONIEC SZYNY B	MIEJSCE NA KRZESEŁKO C	POZYCJA ZATRZYMANIA D
150	313	540	236
165	325	550	248
185	341	565	263